

**SOLUZIONE PER IL LAVAGGIO - LINEA LM**  
**WASHING SOLUTION - LM SERIES**

**LAVATRICI SUPERCENTRIFUGANTI LM 100/125 KG**  
**HIGH SPIN WASHING MACHINES LM 100/125 KG**

**IM11 - UX e UI all'avanguardia**  
per una maggiore interazione uomo macchina.

**IM11 - advanced UX and UI**  
for more human-machine interaction.

**Easy to use**

Easy Unload: rotazione del cesto per scarico facilitato della biancheria.

**Easy to use**

Easy Unload: automatic drum rotation to facilitate the unloading of the linen.

**Affidabilità e manovrabilità**

Doppia chiusura pneumatica e ampia apertura della porta a 180°.

**Reliability and maneuverability**  
Double pneumatic door lock system and 180° door opening.

**Sicurezza**

Fissaggio di sicurezza attraverso tirafondi (non forniti).

**Security**

Need of fixing to the floor (not included).



**Gestione a 360°**  
Controllo dei cicli di lavaggio in Wi-Fi attraverso IM11, portale I'M CONNECT e App.

**360° management**  
Wi-fi control of the washing cycles through IM11, I'M CONNECT portal and App.

**Personalizzazione cicli**

Gestione totale dei parametri di lavoro.  
**Customization of cycles**  
Total management of working parameters.

**Carico acqua bilanciato**

Carico acqua calda e fredda bilanciato per il risparmio energetico.  
**Balanced water fill**  
Hot and cold water mixed during filling phase for energy saving.

**Struttura in acciaio INOX AISI 304**

Fronte, pannelli laterali, superiore, cesto, stella cesto e vasca in acciaio INOX.  
**AISI 304 stainless steel structure**  
STAINLESS STEEL front, sides, top, drum, spider and outer drum.

Kit allacciamento fino a 11 pompe peristaltiche per detersivo liquido + Flush di serie  
Standard connection kit for up to 11 peristaltic pumps for liquid detergent + Flush

\*Necessita di aria compressa / \*Compressed air requested



SCANSIONA PER ALTRE INFO  
SCAN FOR MORE INFO

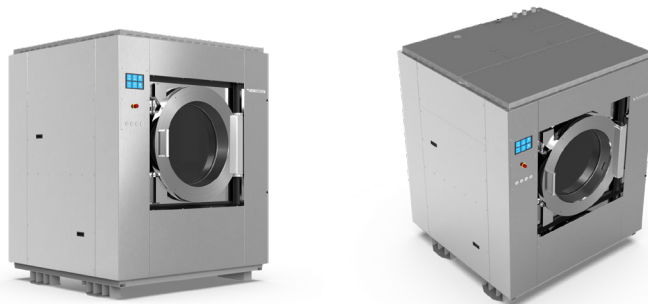

Wet Cleaning Ready



SCANSIONA PER ALTRE INFO  
SCAN FOR MORE INFO

**OPTIONAL e ACCESSORI / OPTIONS and ACCESSORIES**

- Sistemi di dosaggio automatici detersivi da 1 a 6 pompe peristaltiche / Automatic detergent dosing systems from 1 to 6 peristaltic pumps
- Kit 2 tubi di carico acqua in rete metallica da 1 inch 1/2 / Kit of two pieces 1 1/2 inch metal mesh water load pipes
- Valvola ingresso acqua dura / Hard water inlet
- Seconda valvola di scarico per circuito di recupero / Second drain valve for recovery circuit
- Sistema di scarico/carico biancheria a 1 o 2 vie (tilting1 o 2) / Loading/unloading laundry system at 1 or 2 way (tilting1 or 2)
- Sistema di pesatura biancheria (celle di carico) / laundry weighing system (with load cells)

DATI TECNICI / TECHNICAL DATA	LM 100	LM 125
-------------------------------	--------	--------

- Capacità 1:9 - 1:10 / Capacity 1:9 - 1:10	111 - 101 Kg (245 - 223 lb)	139 - 125 Kg (306 - 276 lb)
- Diametro cesto Ø / Drum diameter Ø	1270 mm (50 inch.)	1270 mm (50 inch.)
- Profondità cesto / Drum depth	878 mm (34.5 inch.)	1074 mm (42 inch.)
- Volume cesto / Drum volume	1000 lt	1250 lt
- Diametro di carico Ø / Load diameter Ø	710 mm (28 inch.)	710 mm (28 inch.)
- Velocità di centrifuga / Spin speed	700 r.p.m.	700 r.p.m.
- Fattore G / G Factor	347	347
- Intensità sonora / Air sound intensity	69 dB (A)	69 dB (A)
- Perdite al mantello / Heating leakage	7 %	7 %
- Carico dinamico (frequenza) / Dynamic load (frequency)	32466 N (541 Hz)	30758 N (512,6 Hz)
- Consumo acqua fredda* / Cold water consumption*	1100 l (38.8 ft³)	1375 l (48.5 ft³)
- Consumo acqua calda* / Hot water consumption*	210 l (7.4 ft³)	263 l (9.3 ft³)
- Consumo acqua* / Water consumption*	1310 l (46 ft³)	1638 l (58 ft³)
- Portata scarico / Drain flow	200 lt/min (7 ft³/min)	400 lt/min (14 ft³/min)
- Consumo aria compressa-cliclo / Compressed air consumption-cycle	10 l (0.35 ft³)	10 l (0.35 ft³)
- Dimensioni macchina: LxPxH / Machine dimension WxDxH (100 mm = 3.93 inch.)	1700x1644x2105 mm	1700x1834x2105 mm
- Peso netto / Net weight	1990 Kg (4387 lb)	2074 Kg (4572 lb)
- Dimensioni imballo: LxPxH / Packing dimension WxDxH (100 mm = 3.93 inch.)	1740x1740x2260 mm	1800x1930x2260mm
- Peso lordo / Gross weight	2050 Kg (4519 lb)	2141 Kg (4720 lb)
- Volume imballo / Packaging volume	6,8 mc (240 ft³)	7,8 mc (275.5 ft³)
- Macchine imballate STD per container 20' / STD. packed machines in to 20' container	3 pz.	3 pz.
- Macchine imballate STD per container 40' / STD. packed machines in to 40' container	6 pz.	6 pz.

**DATI PER TIPOLOGIA DI RISCALDAMENTO / DATA BY TYPE OF HEATING**

- Consumo vapore* (macchine vapore) / Steam heating consumption* (steam machines)	2,7 kg (6 lb)	3,4 kg (7.5 lb)
- Assorbimento elettrico / Electric absorption (macchine vapore, hot water / steam, hot water machines)	12 kWh	15 kWh

3ph400V-480V(+N) / 3ph230V / 1ph230V 50/60Hz

\* Lavaggio "Cotone" 60° C, / Cycle "Cotton" 60° C - EN60456, tab. A2

- Pos. 1 - Acqua fredda 1 1/2" \ Cold water 1 1/2" - Press. 0,5 ÷ 10 bar
- Pos. 2 - Acqua calda 1 1/2" \ Hot water 1 1/2" - Press. 0,5 ÷ 10 bar
- Pos. 3 - Entrata vapore 1 1/4" \ Steam inlet 1 1/4" - max 9,5 bar
- Pos. 4 - Scarico acqua / Drain valve LM 100 Ø 80 mm (3 inch.)  
LM 125 2 x 80 (2 x 3 inch.)
- Pos. 5 - Sfiato Ø 80 mm (3 inch.) / Air vent Ø 80 mm (3 inch.)
- Pos. 6 - Aria compressa 10 bar /  
10 bar Compressed air Ø 12 mm (0.47 inch.)
- Pos. 7 - Alimentazione elettrica / Electrical power supply
- Pos. 9 - Scomparti detersivo n. 4 / Detergent boxes n. 4
- Pos. 10 - Scarico acqua (solo 125) / Drain valve (only 125)

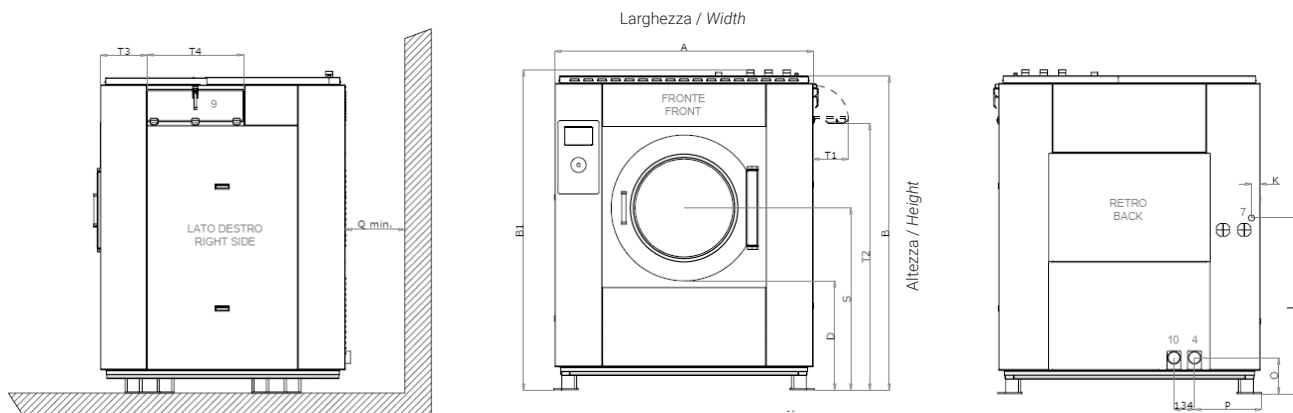
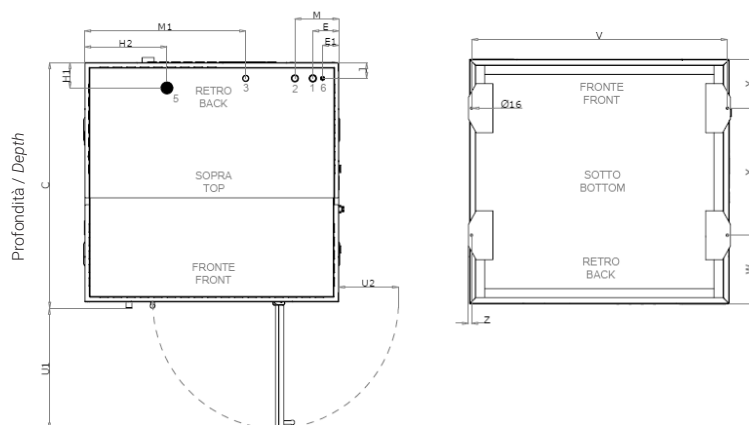

100 mm = 3.93 inch. - fattore di conversione 1 / 25,4 \ factor conversion 1 / 25,4

Modalità di ancoraggio: necessita di Fischer (non inclusi) / Fixing modality: fischer needs (not included)

[mm]	A	B	C	D	E	E1	H1	H2	J	K	L	M	M1	O	P	Q <sub>min</sub>	S	T1	T2	T3	T4	U1	U2	V	W	X	Y	Z
<b>LM 100</b>	1700	2065	1644	717	173.5	108.5	169	549.5	105	57	1142.5	293.5	1076.5	235	434	600	1197	233	1752.5	300	630	810	400	1674	449	830.5	320	20
<b>LM 125</b>	1700	2065	1834	717	173.5	108.5	169	549.5	105	57	1142.5	293.5	1076.5	235	434	600	1197	233	1752.5	300	630	810	400	1674	449	1020.5	320	20

**SOLUZIONE PER IL LAVAGGIO - LINEA LM**  
**WASHING SOLUTION - LM SERIES**

**LAVATRICI SUPERCENTRIFUGANTI LM TILTING\* 100 - 125 KG**  
**HIGH SPIN WASHING MACHINES LM TILTING\* 100 - 125 KG**

**IM11 - UX e UI all'avanguardia**  
per una maggiore interazione uomo macchina.

**IM11 - advanced UX and UI**  
for more human-machine interaction.

**Easy to use**

Easy dowload: rotazione del cesto per scarico facilitato della biancheria.

**Easy to use**

Easy dowload: automatic drum rotation to facilitate the unloading of the linen.

**Affidabilità e manovrabilità**

Doppia chiusura pneumatica e ampia apertura della porta a 180°.

**Reliability and maneuverability**  
Double pneumatic door lock system and 180° door opening.

**Sistema tilting**

Tilting 1: scarico a una via.

Tilting 2 : scarico/scarico a due vie.

**Tilting system**

Tilting 1: unloading at 1 way.

Tilting 2: Loading/unloading at 2 ways.

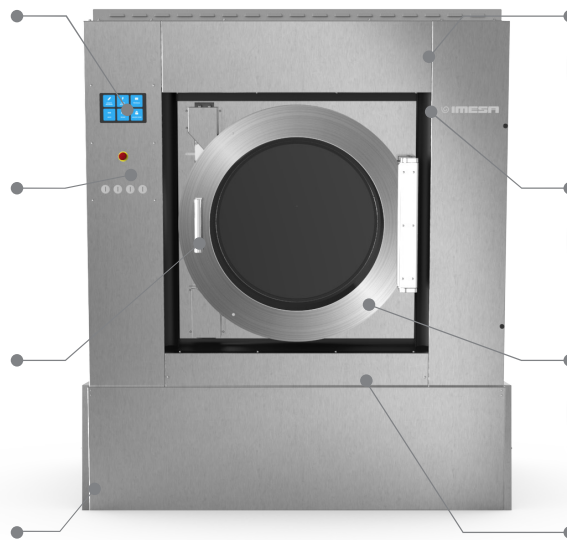

**Gestione a 360°**  
Controllo dei cicli di lavaggio in Wi-Fi attraverso IM11, portale I'M CONNECT e App.

**360° management**  
Wi-fi control of the washing cycles through IM11, I'M CONNECT portal and App.

**Personalizzazione cicli**

Gestione totale dei parametri di lavoro.

**Customization of cycles**

Total management of working parameters.

**Carico acqua bilanciato**

Carico acqua calda e fredda bilanciato per il risparmio energetico.

**Balanced water fill**

Hot and cold water mixed during filling phase for energy saving.

**Struttura in acciaio INOX AISI 304**  
Fronte, pannelli laterali, superiore, cesto, stella cesto e vasca in acciaio INOX.

**AISI 304 stainless steel structure**  
STAINLESS STEEL front, sides, top, drum, spider and outer drum.

Kit allacciamento fino a 11 pompe peristaltiche per detersivo liquido + Flush di serie  
Standard connection kit for up to 11 peristaltic pumps for liquid detergent + Flush

\*Necessita di aria compressa / \*Compressed air requested



SCANSIONA PER ALTRE INFO  
SCAN FOR MORE INFO



Wet Cleaning Ready



SCANSIONA PER ALTRE INFO  
SCAN FOR MORE INFO

**OPTIONAL e ACCESSORI / OPTIONS and ACCESSORIES**

- Sistemi di dosaggio automatici detersivi da 1 a 6 pompe peristaltiche / Automatic detergent dosing systems from 1 to 6 peristaltic pumps
- Kit 2 tubi di carico acqua in rete metallica da 1 inch 1/2 / Kit of two pieces 1 1/2 inch metal mesh water load pipes
- Valvola ingresso acqua dura / Hard water inlet
- Seconda valvola di scarico per circuito di recupero / Second drain valve for recovery circuit

## DATI TECNICI / TECHNICAL DATA

LM Tilting 100

LM Tilting 125

- Capacità 1:9 - 1:10 / Capacity 1:9 - 1:10	111 - 101 Kg (245 - 223 lb)	139 - 125 Kg (306 - 276 lb)
- Diametro cesto Ø / Drum diameter Ø	1270 mm (50 inch.)	1270 mm (50 inch.)
- Profondità cesto / Drum depth	878 mm (34.5 inch.)	1074 mm (42 inch.)
- Volume cesto / Drum volume	1000 lt	1250 lt
- Diametro di carico Ø / Load diameter Ø	710 mm (28 inch.)	710 mm (28 inch.)
- Velocità di centrifuga / Spin speed	700 r.p.m.	700 r.p.m.
- Fattore G / G Factor	347	347
- Intensità sonora / Air sound intensity	69 dB (A)	69 dB (A)
- Perdite al mantello / Heating leakage	7 %	7 %
- Carico dinamico (frequenza) / Dynamic load (frequency)	32466 N (541 Hz)	30758 N (512 Hz)
- Consumo acqua fredda* / Cold water consumption*	1100 l (38.8 ft³)	1375 l (48.5 ft³)
- Consumo acqua calda* / Hot water consumption*	210 l (7.4 ft³)	263 l (9.3 ft³)
- Consumo acqua* / Water consumption*	1310 l (46 ft³)	1638 l (58 ft³)
- Portata scarico / Drain flow	200 lt/min (7 ft³/min)	400 lt/min (7 ft³/min)
- Consumo aria compressa-ciclo / Compressed air consumption-cycle	10 l (0.35 ft³)	10 l (0.35 ft³)
- Dimensioni macchina: LxPxH <sup>min</sup> - H <sup>max</sup> / Machine dimension WxDxH <sup>min</sup> - H <sup>max</sup> (100 mm = 3.93 inch.)	1783x1670x2170-2405 mm	1783x1860x2170-2405 mm
- Peso netto / Net weight	2088 Kg (4603 lb)	2172 Kg (4788 lb)
- Dimensioni imballo: LxPxH / Packing dimension WxDxH (100 mm = 3.93 inch.)	1800x1930x2320 mm	1800x1930x2320 mm
- Peso lordo / Gross weight	2150 Kg (4730 lb)	2241 Kg (4940 lb)
- Volume imballo / Packaging volume	8 mc (282.5 ft³)	8 mc (282.5 ft³)
- Macchine imballate STD per container 20' / STD. packed machines in to 20' container	3 pz.	3 pz.
- Macchine imballate STD per container 40' / STD. packed machines in to 40' container	6 pz.	6 pz.

## DATI PER TIPOLOGIA DI RISCALDAMENTO / DATA BY TYPE OF HEATING

- Consumo vapore* (macchine vapore) / Steam heating consumption* (steam machines)	2,7 kg (6 lb)	3,4 kg (7.5 lb)
- Assorbimento elettrico / Electric absorption 3ph400V-480V(+N) / 3ph230V / 1ph230V 50/60Hz	9 kWh	9 kWh

\* Lavaggio "Cotone" 60° C, / Cycle "Cotton" 60° C - EN60456, tab. A2

- Pos. 1 - Acqua fredda 1 1/2" \ Cold water 1 1/2" - Press. 0,5 ÷ 10 bar
- Pos. 2 - Acqua calda 1 1/2" \ Hot water 1 1/2" - Press. 0,5 ÷ 10 bar
- Pos. 3 - Entrata vapore 1 1/4" \ Steam inlet 1 1/4" - max 9,5 bar
- Pos. 4 - Scarico acqua / Drain valve LM 100 Ø 80 mm (3 inch.)  
LM 125 2 x 80 (2 x 3 inch.)
- Pos. 5 - Sfiato Ø 80 mm (3 inch.) / Air vent Ø 80 mm (3 inch.)
- Pos. 6 - Aria compressa 10 bar /  
10 bar Compressed air Ø 12 mm (0.47 inch.)
- Pos. 7 - Alimentazione elettrica / Electrical power supply
- Pos. 9 - Scomparti detersivo n. 4 / Detergent boxes n. 4
- Pos. 10 - Scarico acqua (solo 125) / Drain valve (only 125)

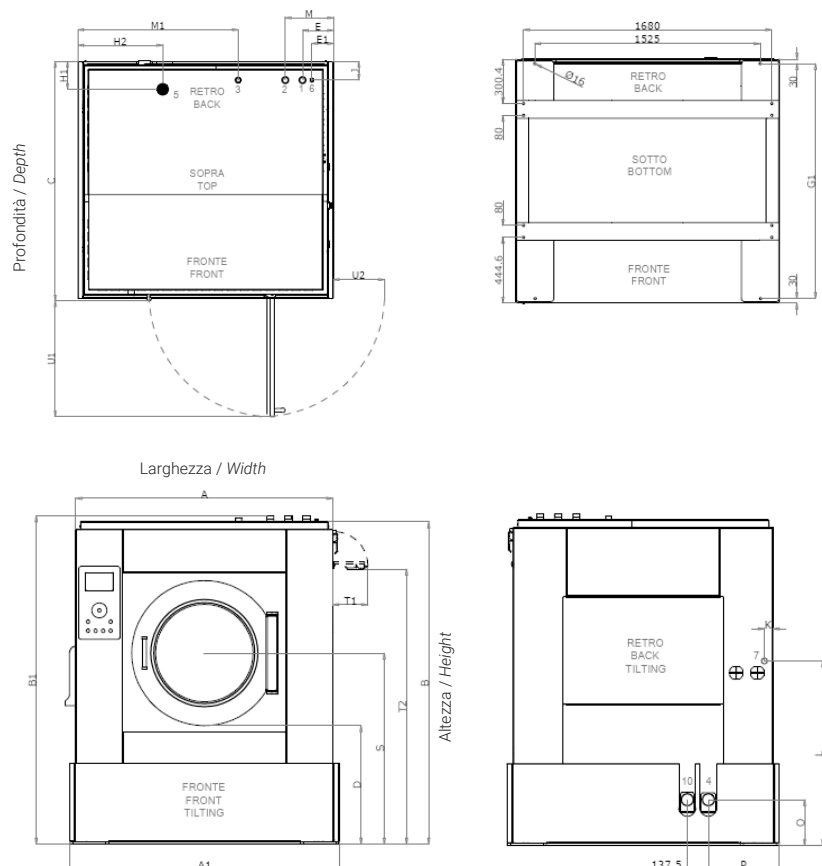

100 mm = 3.93 inch. - fattore di conversione 1 / 25,4 \ factor conversion 1 / 25,4

Modalità di ancoraggio: necessita di Fischer (non inclusi) / Fixing modality: fischer needs (not included)

[mm]	A1	B1	C	D	E	E1	F	G1	H1	H2	J	K	L	M	M1	O	P	Qmin	S	T1	T2	T3	T4	U1	U2
LM 100 t.	1783	2170	1670	782	215.5	150.5	300	1590	194	591.5	130.5	57	1207.5	335.5	1118.5	300	464	600	1262.5	233	1817.5	300	630	810	357
LM 125 t.	1783	2170	1670	782	215.5	150.5	300	1780	194	591.5	130.5	57	1207.5	335.5	1118.5	300	464	600	1262.5	233	1817.5	300	630	810	357