

SOLUZIONE PER IL LAVAGGIO - LINEA LM
WASHING SOLUTION - LM SERIES

LAVATRICI SUPERCENTRIFUGANTI LM 26 - 32 KG
HIGH SPIN WASHING MACHINES LM 26 - 32 KG

IM11 - UX e UI all'avanguardia
per una maggiore interazione uomo macchina.
Etichetta interattiva Tap.Tech.

IM11 - advanced UX and UI
for more human-machine interaction.
Tap.Tech. interactive label.

Smart control
Sistema di gestione dei carichi difficili e personalizzazione dei parametri del ciclo.

Smart control
Smart laundry weighing system and customization of the cycle parameters.

Affidabilità e manovrabilità
Chiusura oblo meccanica e guarnizione conica.

Reliability and maneuverability
Mechanical door lock system and conical door gasket.

Ridotte vibrazioni esilenziosità
Nuova guarnizione fronte lavatrice e perni di supporto oblo.

Reduced vibrations and silence
New front washer gasket and door lock support pins.

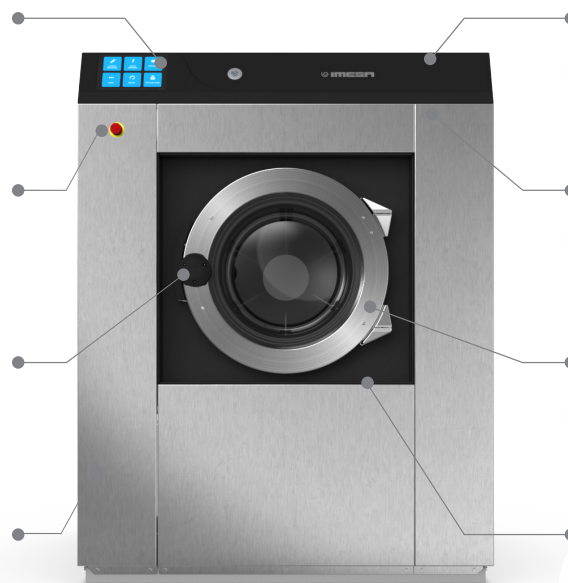

Gestione a 360°
Controllo dei cicli di lavaggio in Wi-Fi attraverso IM11, portale IM CONNECT e App.

360° management
Wi-fi control of the washing cycles through IM11, IM CONNECT portal and App.

Migliore ergonomia
Pannello comandi nero inclinato per migliore visibilità e oblo satinato.

Better ergonomics
Black control panel tilted for better visibility and glazing door.

Acciaio INOX AISI 304 di SERIE
su cesto, stella cesto e vasca. Fronte, pannelli laterali e top in acciaio INOX AISI 304 su richiesta.

STANDARD AISI 304 stainless steel
on drum, spider and outer drum. Front, top and side panels in INOX 304 on request.

Elevata efficienza in centrifuga
Cinghie di trasmissione in poly-v, sistema di controllo con riduzione sbilanciamento.

High efficiency in centrifuge
Poly-v transmission belts, spin control system with reduction of dynamic imbalance.



SCANSIONA PER ALTRE INFO
SCAN FOR MORE INFO



Wet Cleaning Ready



SCANSIONA PER ALTRE INFO
SCAN FOR MORE INFO

OPTIONAL e ACCESSORI / OPTIONS and ACCESSORIES

- Kit allacciamento fino a 11 pompe peristaltiche per detersivo liquido + Flush / Connection kit for up to 11 peristaltic pumps for liquid detergent + Flush
- Sistemi di dosaggio automatici detersivi da 1 a 6 pompe peristaltiche / Automatic detergent dosing systems from 1 to 6 peristaltic pumps
- Kit pompa di scarico (solo per modelli 1ph 230V) / Drain pump kit (for model 1ph 230V only)
- Kit 2 tubi di carico acqua in rete metallica da 3/4 inch / Kit of two pieces 3/4 inch metal mesh water load pipes
- Fronte, top e pannelli laterali in INOX 18/10 AISI 304 / Front, top and side panels in 18/10 AISI 304 STAINLESS STEEL
- Sistema di pesatura biancheria (celle di carico) / laundry weighing system (with load cells)
- Apertura oblo sinistrorsa / Left-hand door opening
- Valvola ingresso acqua dura / Hard water inlet valve
- Seconda valvola di scarico per circuito di recupero / Second drain valve for recovery circuit
- Sistema di pesatura biancheria (celle di carico) / laundry weighing system (with load cells)
- Basamento di rialzo con o senza rivestimento in INOX h200 o h300 mm / Crankcase with or without STAINLESS STEEL cover h200 or h300 mm

DATI TECNICI / TECHNICAL DATA

LM 26

LM 32

- Capacità 1:9 - 1:10 / Capacity 1:9 - 1:10	28 - 26 Kg (62 - 57 lb)	36 - 32 Kg (79 - 70 lb)
- Diametro cesto Ø / Drum diameter Ø	855 mm (33.6 inch.)	855 mm (33.6 inch.)
- Profondità cesto / Drum depth	444 mm (17.5 inch.)	557 mm (22 inch.)
- Volume cesto / Drum volume	254 lt	320 lt
- Diametro di carico Ø / Load diameter Ø	380 mm (15 inch.)	380 mm (15 inch.)
- Velocità di centrifuga / Spin speed	915 r.p.m.	915 r.p.m.
- Fattore G / G Factor	400	400
- Intensità sonora / Air sound intensity	65 dB (A)	65 dB (A)
- Perdite al mantello / Heating leakage	5 %	5 %
- Carico dinamico (frequenza) / Dynamic load (frequency)	30 kN (12.25 Hz)	35 kN (15.25 Hz)
- Consumo acqua fredda* / Cold water consumption*	172 l (6.07 ft³)	211 l (7.45 ft³)
- Consumo acqua calda* / Hot water consumption*	50 l (1.7 ft³)	62 l (2.2 ft³)
- Consumo acqua* / Water consumption*	222 l (7.8 ft³)	273 l (9.7 ft³)
- Portata scarico / Drain flow	160 lt/min (5.6 ft³/min)	160 lt/min (5.6 ft³/min)
- Dimensioni macchina: LxPxH / Machine dimension WxDxH (100 mm = 3.93 inch.)	1100x970x1440 mm	1100x1084x1440 mm
- Peso netto / Net weight	535 Kg (1179.4 lb)	548 Kg (1208 lb)
- Dimensioni imballo : LxPxH / Packing dimension WxDxH (100 mm = 3.93 inch.)	1120x1130x1540 mm	1120x1130x1540 mm
- Peso lordo / Gross weight	549,4 Kg (1211.2 lb)	573 Kg (1274 lb)
- Peso lordo gabbia in legno / Gross weight with wooden cage	635 Kg (1399 lb)	750 Kg (1653 lb)
- Peso lordo cassa in legno / Gross weight with wooden case	655 Kg (1444 lb)	770 Kg (1697 lb)
- Volume imballo / Packaging volume	1,95 mc (68.8 ft³)	1,97 mc (69.6 ft³)
- Macchine imballate STD per container 20' / STD. packed machines in to 20' container	10 pz.	10 pz.
- Macchine imballate STD per container 40' / STD. packed machines in to 40' container	20 pz.	20 pz.

DATI PER TIPOLOGIA DI RISCALDAMENTO / DATA BY TYPE OF HEATING

- Riscaldamento elettrico (macchine elettriche, elettrica+vapore) / Electrical Heating (electric, electric+steam machines)	28 kW	29 kW
- Consumo* (macchine elettriche, elettrica+vapore) / Consumption* (electric, electric+steam machines)	2,4 kWh	3,2 kWh
- Assorbimento elettrico (macchine elettriche, elettrica+vapore) / Electric absorption (electric, electric+steam machines)	24 kW	24 kW
- 3ph400V-480V(+N) / 3ph230V / 1ph230V (macchine elettriche, elettrica+vapore) / electric, electric+steam machines)	40 / 69 A	42 / 71 A
- Consumo vapore* (macchine vapore) / Steam heating consumption* (steam machines)	2 Kg (0.9 lb)	4 Kg (1.8 lb)
- Consumo elettrico* (macchine hot-water, vapore) / Electric consumption* (hot-water, steam machines)	1,5 kWh	2,3 kWh
- Assorbimento elettrico (macchine hot-water, vapore) / Electric absorption (hot-water, steam machines)	4 kW	5 kW
- 3ph400V-480V(+N) / 3ph230V / 1ph230V (macchine hot-water, vapore) / hot-water, steam machines)	6 / 10 A	8 / 14 A

* Lavaggio "cotone" 60° C / Cycle "Cotton" 60° C \ EN60456, tab. A2

Durata programmi macchina elettrica: LM 26 40 min, LM32 45 min. /

Total time electrical heating machine: LM 26 40 min., LM 32 45 min.

Pos. 1A - Vapore diretto (solo macchine vapore diretto o indiretto) Ø 3/4" / Direct steam (only direct or indirect steam heated machines)

Pos. 1B - Uscita vapore indiretto (solo per macchine vapore indiretto) / Ø 3/4" Indirect steam exit (only indirect steam heated machines)

Pos. 2 - Sfiato Ø 50 mm (2 inch.) / Vent Ø 50 mm (2 inch.)

Pos. 3 - Acqua calda Ø 3/4" / Hot water Ø 3/4" - Press. 0,5 ÷ 10 bar

Pos. 4 - Acqua fredda Ø 3/4" / Cold water Ø 3/4" - Press. 0,5 ÷ 10 bar

Pos. 5 - Acqua dura (se presente) Ø 3/4" / Hard water (if present) Ø 3/4"

Pos. 6 - Alimentazione elettrica / Electrical power supply

Pos. 7 - Scarico acqua Ø 50 mm (2 inch.) / Drain valve Ø 50 mm (2 inch.)

Pos. 8 - Carico detersivi in polvere / Powder detergent load

Max pressione vapore 9,5 bar / 9,5 bar max steam pressure

Pressione vapore consigliata 5 bar / Recommended steam pressure 5 bar

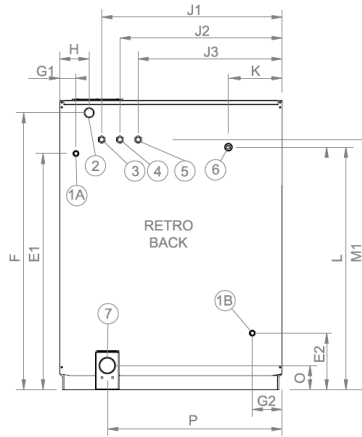
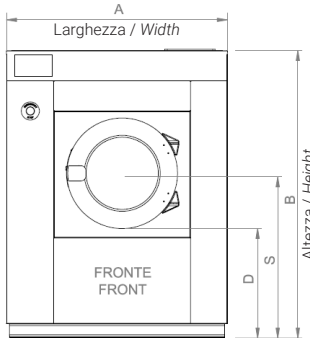
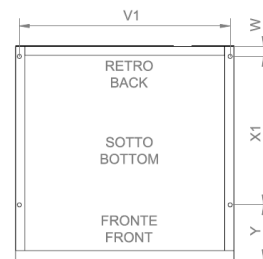
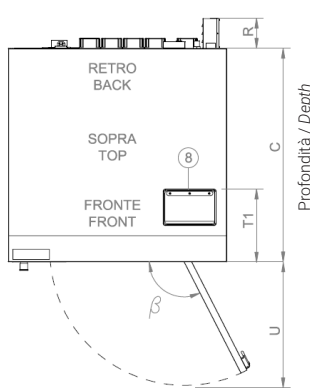
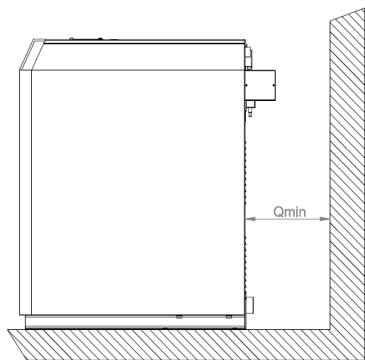

100 mm = 3.93 inch. - fattore di conversione 1 / 25,4 \ factor conversion 1 / 25,4

[mm]	A	B	C	D	E1	E2	F	G1	G2	H	J1	J2	J3	K	L	M1	O	P	Q _{min}	R	S	T1	U	V1	W	X1	Y	β
LM 26	1100	1440	970	580	1100	320	1355	90	110	90	945	835	725	600	1170	1340	120	850	600	155	850	250	600	1010	312	586	70	155°
LM 32	1100	1440	1084	580	1100	320	1355	90	110	90	945	835	725	600	1170	1340	120	850	600	155	850	250	600	1010	312	700	70	155°



imesa.it

Via degli Olmi 22 31040 Cessalto TV Italia - info@imesa.it

