

SOLUZIONE PER LA STIRATURA - LINEA SMART FI
IRONING SOLUTION - FI SMART SERIES

MANGANI A RULLO SL FI 100 - 120 - 150 Ø 25
FLATWORK IRONERS SL FI 100 - 120 - 150 Ø 25

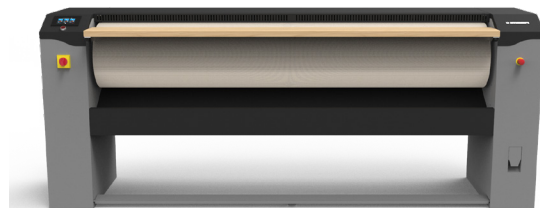

SCANSIONA PER ALTRE INFO
SCAN FOR MORE INFO

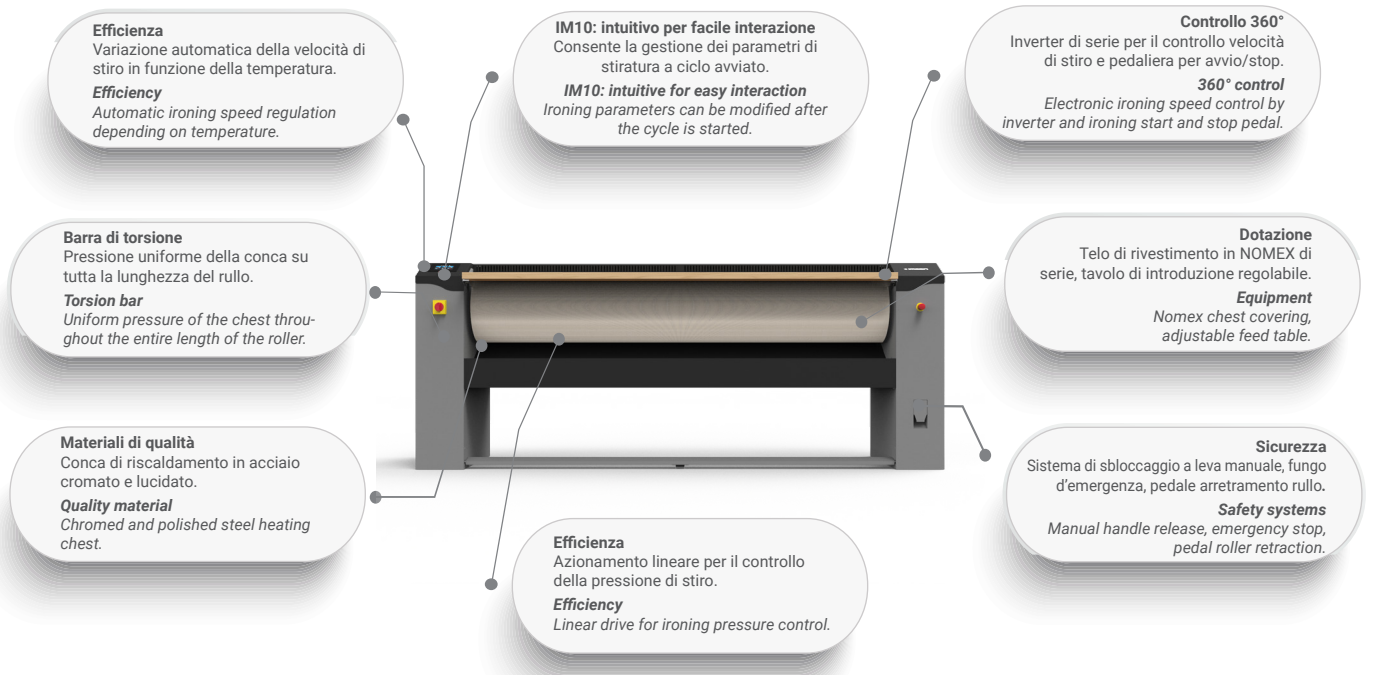

CONTROLLO DELLA PRESSIONE
-Tecnologia brevettata - TV2008A000116
PRESSURE CONTROL
- Patented technology - TV2008A000116



CON IoT
WITH IoT

OPTIONAL e ACCESSORI / OPTIONS and ACCESSORIES

- Rivestimento rullo a molle / Roller with metal mesh covering
- Sistema di aspirazione / Vacuum system
- IoT (connessione wi-fi) per controllo macchina da remoto / IoT (wi-fi connections) for remote machine control
- Raccogliitore per biancheria in entrata / Collector for incoming laundry

DATI TECNICI* / TECHNICAL DATA*

SL FI 100 Ø25

SL FI 120 Ø25

SL FI 150 Ø25

- Lunghezza utile di stiro / Ironing surface	1000 mm (39.3 inch.)	1200 mm (47.2 inch.)	1500 mm (59 inch.)
- Diametro del rullo Ø / Roller diameter Ø	250 mm (9.8 inch.)	250 mm (9.8 inch.)	250 mm (9.8 inch.)
- Produzione oraria** / Hourly production**	25 kg/h (55 lb/h)	30 kg/h (66 lb/h)	35 kg/h (77 lb/h)
- Evaporazione** / Evaporation**	5 lt/h	6 lt/h	7 lt/h
- Velocità di rotazione / Rotation speed	1÷6 mt/min	1÷6 mt/min	1÷6 mt/min
- Pressione di stiro / Ironing pressure	214÷322 kg/m ²	214÷322 kg/m ²	214÷322 kg/m ²
- Scarico aria umida (pos. 1) Ø / Humid air (pos. 1) Ø	(opt.) 80 mm (3.1 inch.)	(opt.) 80 mm (3.1 inch.)	(opt.) 80 mm (3.1 inch.)
- Portata aria umida / Humid air flowrate	(opt.) 160 m ³ /h	(opt.) 160 m ³ /h	(opt.) 160 m ³ /h
- Intensità sonora area / Air sound intensity	46 db (A)	46 db (A)	46 db (A)
- Emissione di calore (% potenza installata)*** / Heating emission (maximum power)***	3 %	3 %	3 %
- Filetto piedini / Feet thread	M10	M10	M10
- Dimensioni macchina: LxPxH / Machine dimension : WxDxH (100 mm = 3.93 inch.)	1550x643x985 mm	1750x643x985 mm	2050x643x985 mm
- Peso netto / Net weight	159 Kg (350.5 lb)	174 Kg (383.6 lb)	198 Kg (436.5 lb)
- Dimensioni imballo standard: LxPxH / Standard packing dimension WxDxH (100 mm = 3.93 inch.)	1600x645x1140 mm	1800x645x1140 mm	2100x645x1140 mm
- Dimensione imballo in gabbia di legno: LxPxH / Wooden cage dimension WxDxH (100 mm = 3.93 inch.)	1668x713x1294 mm	1868x713x1294 mm	2168x713x1294 mm
- Peso lordo / Gross weight	176 Kg (388 lb)	192 Kg (423.2 lb)	218 Kg (480.6 lb)
- Volume imballo standard / Standard packaging volume	1,17 mc (41.3 ft ³)	1,32 mc (45.9 ft ³)	1,54 mc (54.3 ft ³)
- Volume imballo in gabbia di legno / Wooden cage packaging volume	1,54 mc (54.3 ft ³)	1,72 mc (60.7 ft ³)	2 mc (70.6 ft ³)
- Macchine imballate STD per container 20' / STD. packed machines in to 20' container	24 pz.****	18 pz.****	18 pz.****
- Macchine imballate STD per container 40' / STD. packed machines in to 40' container	50 pz.****	36 pz.****	36 pz.****

DATI RISCALDAMENTO ELETTRICO / ELECTRIC HEATING DATA

- Riscaldamento elettrico / Electrical Heating	4,9 kW	5,8 kW	7,3 kW
- Potenza totale (pos. 2) / Total Power (pos 2.)	5,1 kW	6,1 kW	7,5 kW
- Assorbimento / Absorptions (3 ph 400V-440V (+N) / 3 ph 230V / 1 ph 230V 50/60 Hz)	7 / 13 / 22 A	9 / 15 / 26 A	11 / 19 / 33 A
- Consumo orario ** / Hourly consumption**	4,1 kWh	4,9 kWh	6,0 kWh

* I dati sono riferiti a macchine dotate di aspirazione / Data refer to vacuum machines.

** 20% di umidità residua e utilizzo del rullo al 100% (ISO 9398) / 20% of residual humidity and use of 100% of roller lenght (ISO 9398).

*** % di potenza massima installata / % of maximum installed power

**** Macchine sovrapposte in container high cube / Stacked machines in high cube containers

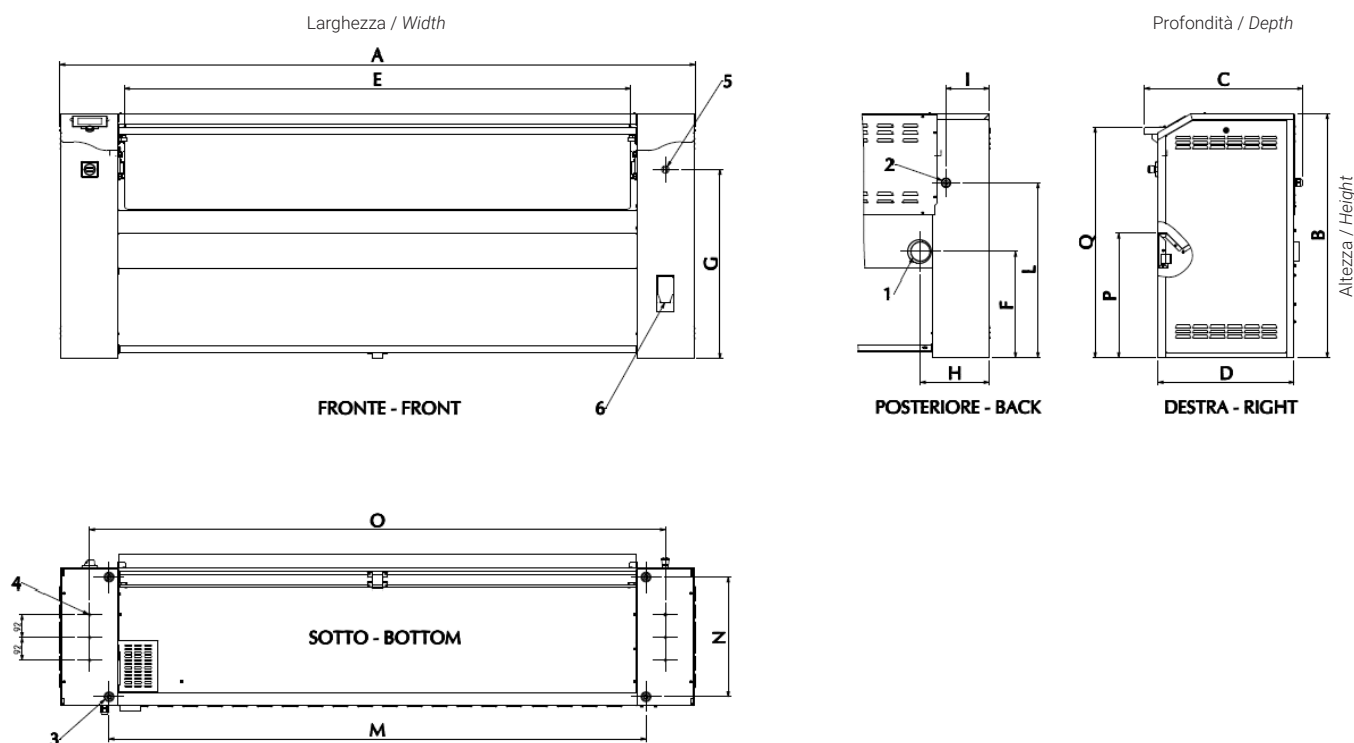

Pos. 1 - Scarico aria umida \ Humid air; Pos. 2 - Alimentazione elettrica / Electrical power supply; Pos. 3 - 4 Piedini (M10) / 4 Feet (M10); Pos. 4 - Fissaggio al suolo (Ø 13mm) / Fixing to the ground (Ø 13mm); Pos. 5 - Pulsante di emergenza / Emergency button; Pos. 6 - Sgancio di sicurezza conca / Chest safety release;

100 mm = 3.93 inch. - fattore di conversione 1 / 25,4 \ factor conversion 1 / 25,4

[mm]	A	B	C	D	E	F	G	H	I	L	M	N	O	P	Q
SL FI 100/25	1550	985	643	552	1030	426	760	279	175	705	1154	480	1310	580	924
SL FI 120/25	1750	985	643	552	1230	426	760	279	175	705	1354	480	1510	580	924
SL FI 150/25	2050	985	643	552	1530	426	760	279	175	705	1654	480	1810	580	924



imesa.it

Via degli Olmi 22 31040 Cessalto TV Italia - info@imesa.it

imesa
designing your clean

SOLUZIONE PER LA STIRATURA - LINEA SMART FI
IRONING SOLUTION - FI SMART SERIES

MANGANI A RULLO SL FI 160 - 180 - 200 Ø 33
FLATWORK IRONERS SL FI 160 - 180 - 200 Ø 33

Efficienza
Variazione automatica della velocità di stiro in funzione della temperatura.
Efficiency
Automatic ironing speed regulation depending on temperature.

IM10: intuitivo per facile interazione
Consente la gestione dei parametri di stiratura a ciclo avviato.
IM10: intuitive for easy interaction
Ironing parameters can be modified after the cycle is started.

Controllo 360°
Inverter di serie per il controllo velocità di stiro e pedaliera per avvio/stop.
360° control
Electronic ironing speed control by inverter and ironing start and stop pedal.

Barra di torsione
Pressione uniforme della conca su tutta la lunghezza del rullo.
Torsion bar
Uniform pressure of the chest throughout the entire length of the roller.

Dotazione
Telo di rivestimento in NOMEX di serie, tavolo di introduzione regolabile.
Equipment
Nomex chest covering, adjustable feed table.

Materiali di qualità
Conca di riscaldamento in acciaio cromato e lucidato.
Quality material
Chromed and polished steel heating chest.

Efficienza
Azionamento lineare per il controllo della pressione di stiro.
Efficiency
Linear drive for ironing pressure control.

Sicurezza
Sistema di sbloccaggio a leva manuale, fungo d'emergenza, pedale arretramento rullo.
Safety systems
Manual handle release, emergency stop, pedal roller retraction.

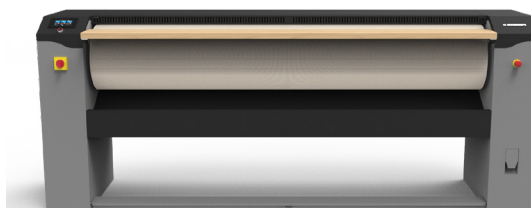

Aspirazione di serie / Standard suction



SCANSIONA PER ALTRE INFO
SCAN FOR MORE INFO



CONTROLLO DELLA PRESSIONE
- Tecnologia brevettata - TV2008A000116
PRESSURE CONTROL
- Patented technology - TV2008A000116



CON IoT
WITH IoT

OPTIONAL e ACCESSORI / OPTIONS and ACCESSORIES

- Rivestimento rullo a molle / *Roller with metal mesh covering*
- IoT (connessione wi-fi) per controllo macchina da remoto / *IoT (wi-fi connections) for remote machine control*
- Raccogliitore per biancheria in entrata / *Collector for incoming laundry*

DATI TECNICI* / TECHNICAL DATA*

SL FI 160 Ø33

SL FI 180 Ø33

SL FI 200 Ø33

- Lunghezza utile di stiro / Ironing surface	1600 mm (62.9 inch.)	1800 mm (70.8 inch.)	2000 mm (78.7 inch.)
- Diametro del rullo Ø / Roller diameter Ø	330 mm (12.9 inch.)	330 mm (12.9 inch.)	330 mm (12.9 inch.)
- Produzione oraria** / Hourly production**	40 kg/h (88 lb/h)	50kg/h (110 lb/h)	60 kg/h (132 lb/h)
- Evaporazione** / Evaporation**	8 lt/h	10 lt/h	12 lt/h
- Velocità di rotazione / Rotation speed	1÷6 mt/min	1÷6 mt/min	1÷6 mt/min
- Pressione di stiro / Ironing pressure	214÷322 kg/m ²	214÷322 kg/m ²	214÷322 kg/m ²
- Scarico aria umida (pos. 1) Ø / Humid air (pos. 1) Ø	80 mm (3.1 inch.)	80 mm (3.1 inch.)	80 mm (3.1 inch.)
- Portata aria umida / Humid air flowrate	160 m ³ /h	160 m ³ /h	160 m ³ /h
- Intensità sonora area / Air sound intensity	46 db (A)	46 db (A)	46 db (A)
- Emissione di calore (% potenza installata)*** / Heating emission (maximum power)***	3 %	3 %	3 %
- Filetto piedini / Feet thread	M10	M10	M10
- Dimensioni macchina: LxPxH / Machine dimension : WxDxH (100 mm = 3.93 inch.)	2150x643x985 mm	2350x643x985 mm	2550x643x985 mm
- Peso netto / Net weight	220 Kg (485 lb)	241 Kg (531.3 lb)	268 Kg (590.8 lb)
- Dimensioni imballo standard: LxPxH / Standard packing dimension WxDxH (100 mm = 3.93 inch.)	2200x645x1140 mm	2400x645x1140 mm	2600x645x1140 mm
- Dimensione imballo in gabbia di legno: LxPxH / Wooden cage dimension WxDxH (100 mm = 3.93 inch.)	2268x713x1294 mm	2468x713x1294 mm	2668x713x1294 mm
- Peso lordo / Gross weight	245 Kg (540 lb)	267 Kg (588.6 lb)	296 Kg (652.5 lb)
- Volume imballo standard / Standard packaging volume	1,61 mc (56.8 ft ³)	1,76 mc (62.1 ft ³)	1,91 mc (67.4 ft ³)
- Volume imballo in gabbia di legno / Wooden cage packaging volume	2.1 mc (74.1 ft ³)	2.3 mc (81.2 ft ³)	2.5 mc (88.2 ft ³)
- Macchine imballate STD per container 20' / STD. packed machines in to 20' container	18 pz.****	6 pz.	6 pz.
- Macchine imballate STD per container 40' / STD. packed machines in to 40' container	36 pz.****	12 pz.	12 pz.

DATI RISCALDAMENTO ELETTRICO / ELECTRIC HEATING DATA

- Riscaldamento elettrico / Electrical Heating	11,1 kW	12,4 kW	13,8 kW
- Potenza totale (pos. 2) / Total Power (pos 2.)	11,3 kW	12,7 kW	14,0 kW
- Assorbimento / Absorptions (3 ph 400V-440V (+N) / 3 ph 230V / 1 ph 230V 50/60 Hz)	16 / 28 / 49 A	18 / 32 / 55 A	20 / 35 / 61 A
- Consumo orario ** / Hourly consumption**	9,0 kWh	10,1 kWh	11,2 kWh

* I dati sono riferiti a macchine dotate di aspirazione / Data refer to vacuum machines.

** 20% di umidità residua e utilizzo del rullo al 100% (ISO 9398) / 20% of residual humidity and use of 100% of roller lenght (ISO 9398).

*** % di potenza massima installata / % of maximum installed power

**** Macchine sovrapposte in container high cube / Stacked machines in high cube containers

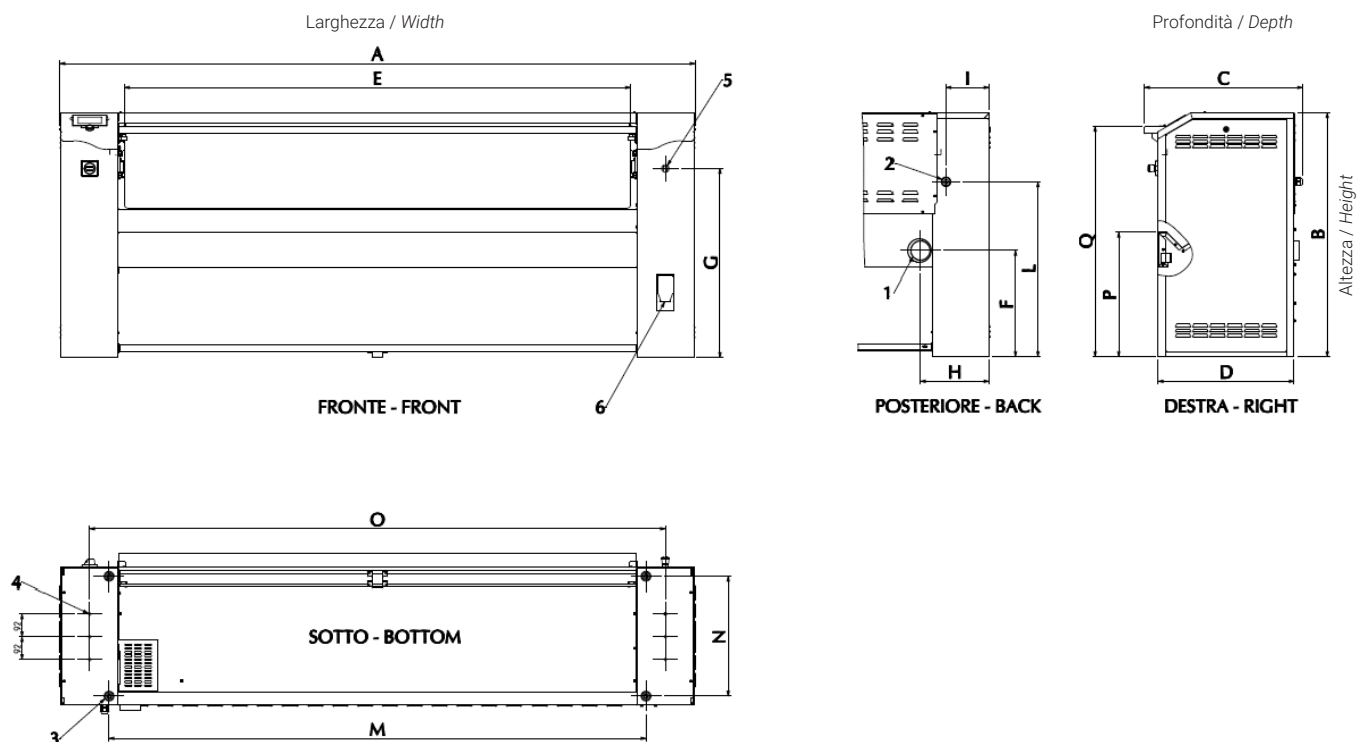

Pos. 1 - Scarico aria umida \ Humid air; Pos. 2 - Alimentazione elettrica / Electrical power supply; Pos. 3 - 4 Piedini (M10) / 4 Feet (M10); Pos. 4 - Fissaggio al suolo (Ø 13mm) / Fixing to the ground (Ø 13mm); Pos. 5 - Pulsante di emergenza / Emergency button; Pos. 6 - Sgancio di sicurezza conca / Chest safety release;

100 mm = 3.93 inch. - fattore di conversione 1 / 25,4 \ factor conversion 1 / 25,4

[mm]	A	B	C	D	E	F	G	H	I	L	M	N	O	P	Q
SL FI 160/33	2150	985	643	552	1630	426	760	279	175	705	1754	480	1910	500	930
SL FI 180/33	2350	985	643	552	1830	426	760	279	175	705	1954	480	2110	500	930
SL FI 200/33	2550	985	643	552	2030	426	760	279	175	705	2154	480	2310	500	930



imesa.it

Via degli Olmi 22 31040 Cessalto TV Italia - info@imesa.it

imesa
designing your clean